

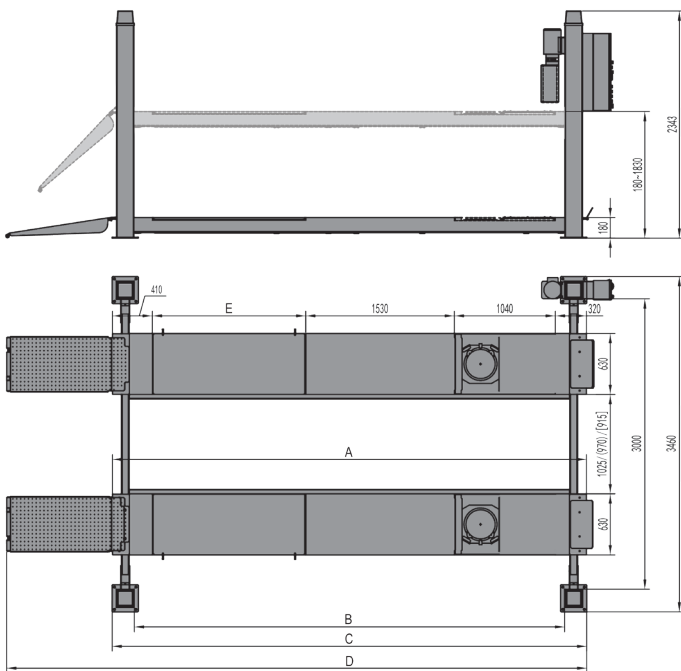

4-POST MOT LIFT L4M/QUXXXMOT

- 4.0t and 5.0t Lifting capacities
- Choice of platform lengths
- Dual revenue lift - ideal for MOTs and wheel alignment work
- Recessed front turn plates, suitable for MOT testing and alignment work
- Rear side slip plate, lockable, covering the rear section of the lift



Accessories

Jacking beam
2.0t - JBA/6225200
2.6t - JBA/6236200

Specifications

Power supply: 400V 3ph/50Hz/16A
Motor power: 2.2kW
Vehicle types: Car, Light Commercial Vehicle
Lifting capacity (4.8m): 4000kg
Lifting capacity (5.2m/5.8m): 5000kg
Lifting/lowering time: 60/55 secs
Installation type: Recessed or surface-mount
Concrete floor min. thickness: 200mm
Overall height: 2343mm

	QU448MOT	QU552MOT	QU558MOT
A	4880mm	5280mm	5780mm
B	4438mm	4838mm	5338mm
C	4888mm	5288mm	5788mm
D	5948mm	6348mm	6848mm
E	1580mm	1980mm	2280mm