

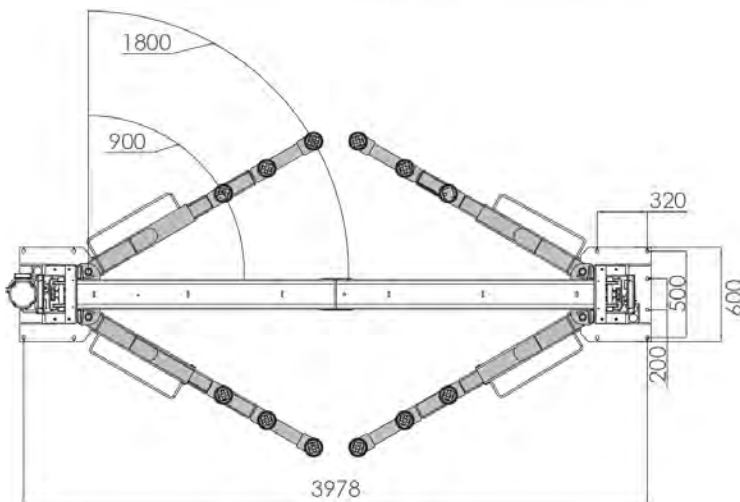

**2-POST LIFT (SEMI-BASE)
L2M/AZ50CH**

- 5.0t Lifting capacity
- 100mm Min. pad height
- 1.9m Max. lifting height
- 3.0m Drive-through width
- Symmetric lifting arms
- Electro-hydraulic operation

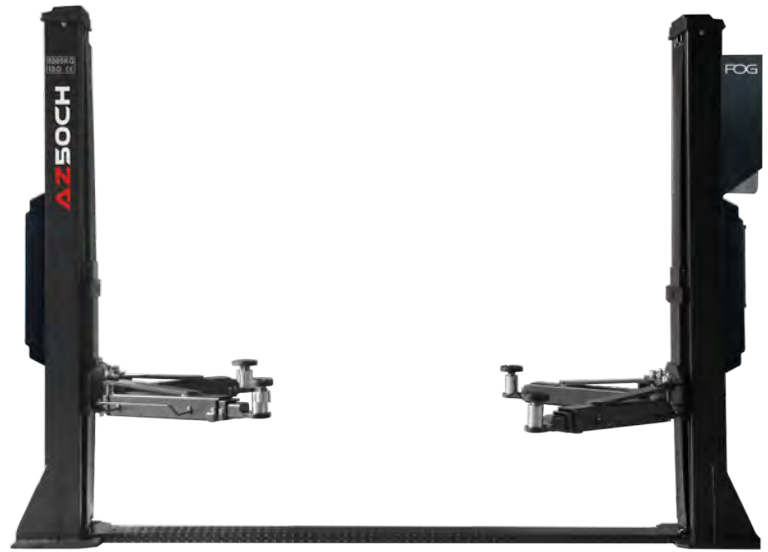

Accessories

Lifting pad extensions
75mm - EV.612035001

Specifications

Front & Rear arm range: 900-1800mm
 Power supply: 400V 3ph/50Hz/20A
 Motor power: 3.5kW
 Vehicle types: Car, Light Commercial Vehicle
 Lifting capacity: 5000kg
 Lifting/lowering time: 45/55 secs
 Installation type: Standard base frame
 Concrete floor min. thickness: 200mm
 Overall height: 2912mm
 Net weight: 997kg

Muller Automotive UK Ltd

Unit 15 Hearder Court,
Beechwood Way,
Plymouth, PL7 5HH
01752 929 929

Sales@MullerAutomotive.co.uk

E&OE. This document's content and data (text and images) are not contractual and subject to change, developments, or improvements, particularly technical ones.