



30" TYRE CHANGER WTM/MDP830AL

- Accommodates rims up to 30"
- Centre post with height adjustment
- Contact-free leverless operation
- Wheel lift to reduce operator strain
- Pneumatic tilting column
- Variable speed control from 0 to 16 rpm
- Synchronised movement of the discs and helper arm



Accessories

Included as standard

- 1 x clamping set inc. 2 cones & wing nut
- 1 x leverless demount head protection set
- 1 x rim breaker blade protection

Specifications

- Clamping capacity: 10" - 30"
- Maximum tyre width: 380mm (15")
- Maximum tyre diameter: 1160mm (46")
- Bead Breaker force: 1.2t
- Operating pressure: 8 - 12bar
- Power supply: 3ph/50Hz
- Motor power: 1.5kW
- Rotation speed: 0 - 16rpm
- Noise level: <70 +/- 3dB (A)
- Net weight: 410kg

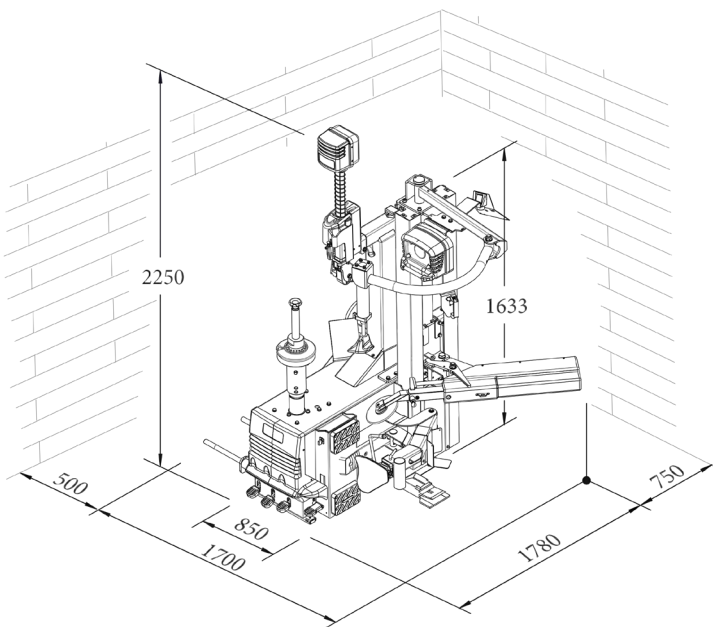

Muller Automotive UK Ltd

Unit 15 Hearder Court,
Beechwood Way,
Plymouth, PL7 5HH
01752 929 929

Sales@MullerAutomotive.co.uk

E&OE. This document's content and data (text and images) are not contractual and subject to change, developments, or improvements, particularly technical ones.