

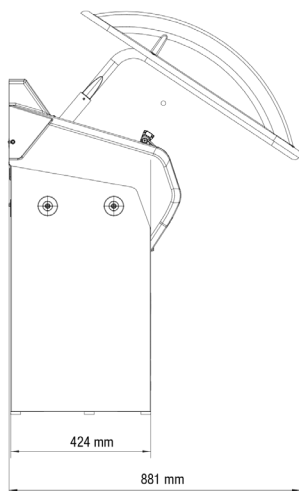

- Virtual Direct Drive system reduces measurement time to under 5 seconds
- AutoAdaptive mode detects weight and dimensions to eliminate steering wheel vibrations.
- Hidden/split weight function helps improve the appearance of the wheel
- Handles wheels up to 75kg in weight

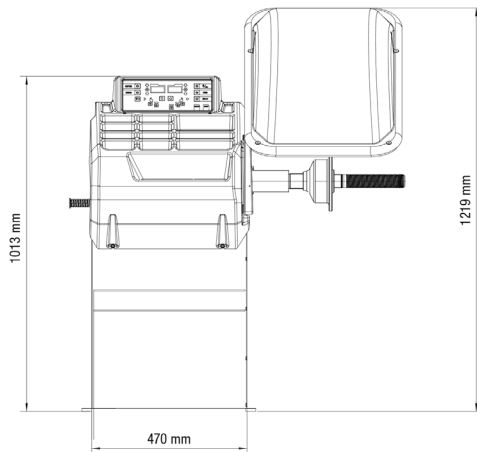

Accessories

Included as standard

- Quick release kit
- 3 Cone kit
- Ground clamp and measuring caliper

Specifications

- Balancing speed: 100rpm
- Measuring cycle: <5s
- Balancing precision: +/- 1g
- Resolution: 1g
- Noise level: <70 +/- 3dB (A)
- Rim width setting range: 40 - 510mm
- Rim diameter setting range: 305 - 660mm
- Maximum width of the tyre: 508mm (20")
- Maximum diameter of the tyre: 1118mm (44")
- Max wheel weight: <75kg
- Net weight: 110kg
- Power supply 230V/50-60HZ

Muller Automotive UK Ltd

Unit 15 Hearder Court,
Beechwood Way,
Plymouth, PL7 5HH
01752 929 929

Sales@MullerAutomotive.co.uk

E&OE. This document's content and data (text and images) are not contractual and subject to change, developments, or improvements, particularly technical ones.