

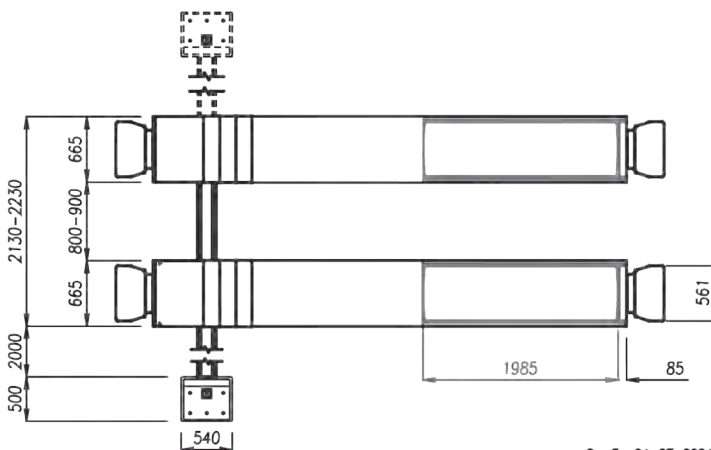

- 4.0t Lifting capacity
- 4.8m Max. platform length
- 2.1m Max. lifting height
- Recessed installation
- Electro-hydraulic operation
- Choice of platform options for servicing, MOT testing, or wheel aligning

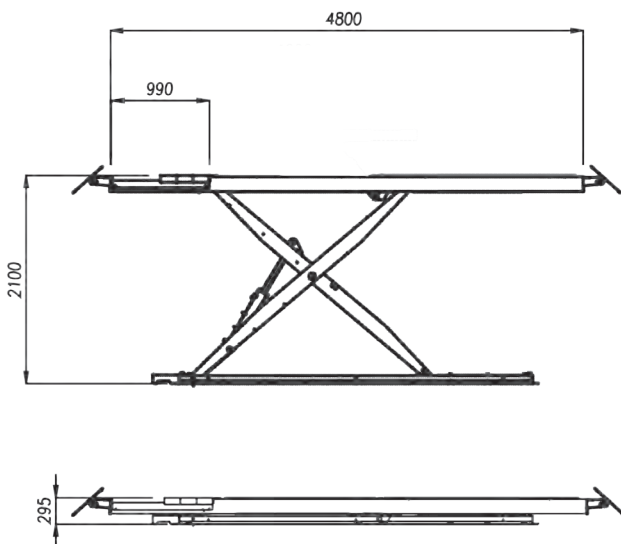

Rev.3 04-07-2024

### Versions

#### LSW/WT40N

Flat platform for servicing

#### LSW/WT40AT

Front recesses & rear slip plates for alignment

#### LSW/WT40ATLT (pictured)

As WT40AT plus 3.5t aux. lifting table

#### LSW/WT40JC

Play detectors & radius plates for ATL MOT testing

#### LSW/WT40JCAT

Dual revenue lift for MOT testing & alignment

### Accessories

#### Jacking beam

2.0t - JBA/6225200 + 6227600

### Specifications

Power supply: 400V 3ph/50Hz

Motor power: 3.0kW

Vehicle types: Car, Light Commercial Vehicle

Lifting capacity: 4000kg

Lifting/lowering time: 40/40 secs

Installation type: Recessed

Concrete floor min. thickness: 160mm

Overall height: 2100mm

Net weight: 2310kg

### Muller Automotive UK Ltd

Unit 15 Hearder Court,  
Beechwood Way,  
Plymouth, PL7 5HH  
01752 929 929

Sales@MullerAutomotive.co.uk

E&OE. This document's content and data (text and images) are not contractual and subject to change, developments, or improvements, particularly technical ones.