

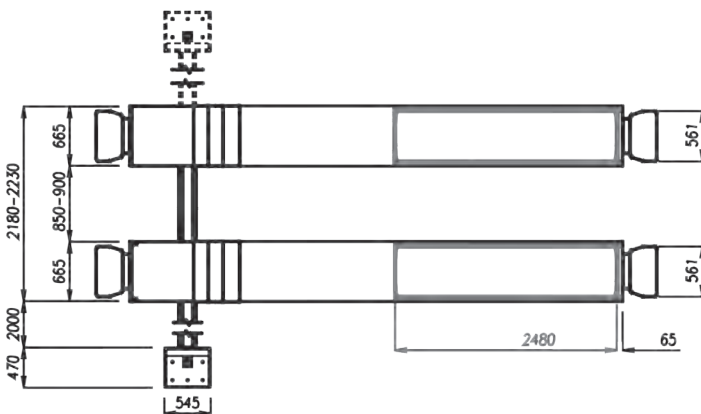

- 5.0t Lifting capacity
- 5.5m Max. platform length
- 2.1m Max. lifting height
- Recessed installation
- Electro-hydraulic operation
- Choice of platform options for servicing, MOT testing, or wheel aligning

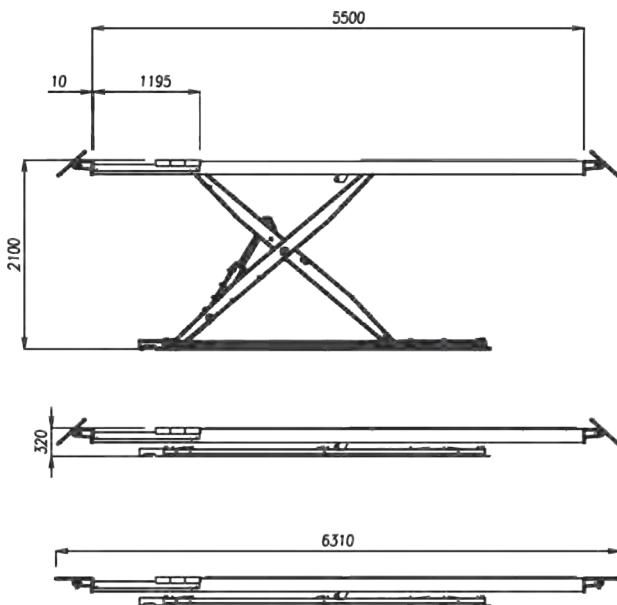

## Versions

### LSW/WL55N

Flat platform for servicing

### LSW/WL55AT

Front recesses & rear slip plates for alignment

### LSW/WL55ATLT (pictured)

As WT40AT plus 3.5t aux. lifting table

### LSW/WL55JC

Play detectors & radius plates for ATL MOT testing

### LSW/WL55JCAT

Dual revenue lift for MOT testing & alignment

## Accessories

### Jacking beam

2.6t - JBA/6236200 + 6227600

## Specifications

Power supply: 400V 3ph/50Hz

Motor power: 3.0kW

Vehicle types: Car, Light Commercial Vehicle

Lifting capacity: 5000kg

Lifting/lowering time: 55/40 secs

Installation type: Recessed

Concrete floor min. thickness: 160mm

Overall height: 2100mm

Net weight: 3780kg

## Muller Automotive UK Ltd

Unit 15 Hearder Court,  
Beechwood Way,  
Plymouth, PL7 5HH  
01752 929 929

Sales@MullerAutomotive.co.uk

E&OE. This document's content and data (text and images) are not contractual and subject to change, developments, or improvements, particularly technical ones.